

Injector Remover

User's Guide

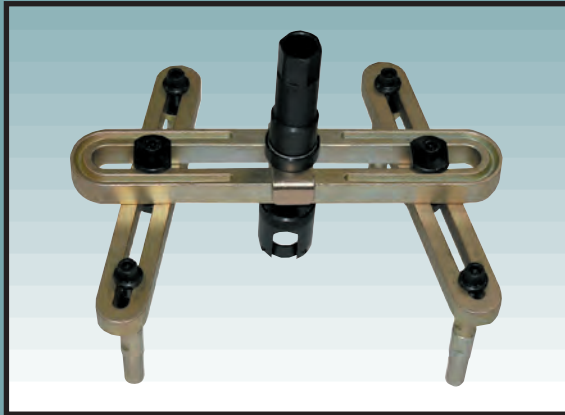

09351 - 4A300

FOREWORD

Injector Remover is a special tool for removing an injector efficiently from the common rail engine in order to prevent damage of cylinder head cover and injector.

This User's Guide aids the understanding for the correct use of this tool. The additional features such as photos, pictures, specifications are oriented around the publication of the manual and applied the most recent specification.

Before using the tool please read User's Guide to the end, and store the User's Guide with the tool for the serviceable use.

The right is reserved to make changes at any time without notice.

Dec. 2006

Printed in Korea

Warning

- 1. Make sure to read this manual to the end. If you do not apply manual process to vehicle, can cause serious damage to Injector remover tool and head cover.**
- 2. Each engine have different using method, surely apply the designated method to suitable vehicle.**

CONTENTS

1. The Limits of Application	2
2. Composition of product	3
3. Components of product	4
4. Caution	7
5. How to use	8
1) Installation and Removal of A, D, U-Engine Injector	8
2) Installation and Removal of J-Engine Injector	12
3) Installation and Removal of S-Engine Injector	17

1. The Limits of Application

Engine	Applicable Vehicle						
	Accent(LC)	Getz(TB)	Elantra(HD)	New Accent(MC)	Matrix(FC)	Sonata(NF)	Granduer(XG)
D-Engine	●	●	●	●	●	●	●
U-Engine		●	●		●		

Engine	Applicable Vehicle						
	Tucson(JM)	Santafe(SM)	Terracan(HP)	Trajet(FO)	H-1 Wagon	H-1 Truck	Veracruz(EN)
D-Engine	●	●		●			
A-Engine					*	*	
J-Engine			●				
S-Engine							●

※ Reference

- : Applicable vehicle
- * : Among 4 injectors, No.2 Injector is available to remove on the vehicle(No.1,3 and 4 are available after removing the engine).

Warning

1. Make sure to read this manual to the end. If you do not apply manual process to vehicle, can cause serious damage to Injector remover tool and head cover.
2. Each engine have different using method, surely apply the designated method to suitable vehicle.

2. Composition of product



Injector Remover Set

- Main Bolt-A
- Injector Holder-A
- Injector Holder-B
- Injector Holder Cover
- Injector Holder Bolt

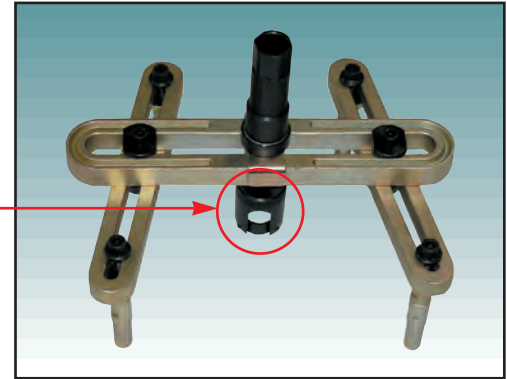

Apply to A,D,U-ENGINE

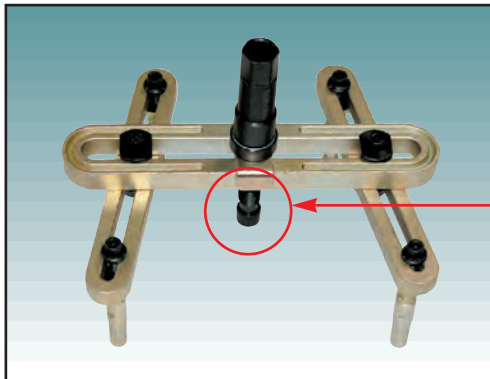

Apply to J-ENGINE

- Main Bolt-B

- Main Bolt-A
- Sub Support-B

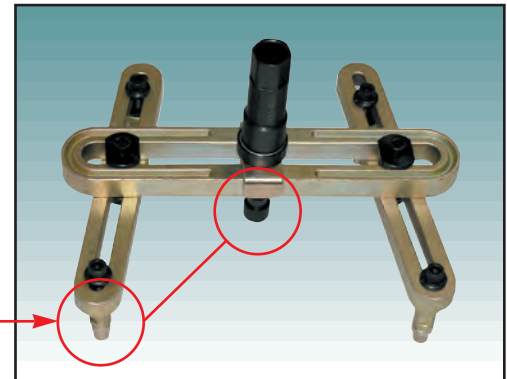

Apply to S-ENGINE

3. Components of product

No.	Tool Name	Tool Number	Quantity	Illustration	Remarks
1	Main Bar	09351-4A300-01	1 EA		
2	Cross Bar	09351-4A300-02	2 EA		
3	Main Bolt Holder	09351-4A300-03	1 EA		
4	Ball Bearing Cover	09351-4A300-04	1 EA		
5	Main Nut-A	09351-4A300-05	1 EA		
6	Main Bolt-A	09351-4A300-06	1 EA		A,D,U,S-ENGINE
7	Main Bolt-B	09351-4A300-07	1 EA		J-ENGINE

Components of product

5

No.	Tool Name	Tool Number	Quantity	Illustration	Remarks
8	Injector Holder-A	09351-4A300-08	1 EA		A,D,U-ENGINE
9	Injector Holder-B	09351-4A300-09	1 EA		A,D,U-ENGINE
10	Injector Holder Cover	09351-4A300-10	1 EA		A,D,U-ENGINE
11	Injector Holder Bolt	09351-4A300-11	2 EA		A,D,U-ENGINE
12	Bar Holder A	09351-4A300-12	2 EA		
13	Bar Holder B	09351-4A300-13	2 EA		
14	Bar Holder Bolt	09351-4A300-14	2 EA		

Components of product

6

No.	Tool Name	Tool Number	Quantity	Illustration	Remarks
15	Support Mounting Bolt	09351-4A300-15	4 EA		
16	Main Support	09351-4A300-16	4 EA		
17	Sub Support-A	09351-4A300-17	4 EA		A,D,U,J-ENGINE
18	Sub Support-B	09351-4A300-18	4 EA		S-ENGINE
19	Main Nut-B	09351-4A300-19	1 EA		Nut when the working space is narrow.
20	Ball Bearing	09351-4A300-20	1 EA		Bearing is consumptive Part (Size:#51105)
21	User's Guide	09351-4A300-21	1 EA		

4. Caution

1) Caution for Installation/Removal of Common Rail Fuel Injection System

- (1) Because the common rail fuel injection system is operating at high pressure (1,600 bar), do not operate it with any function related to Fuel Injection System for 30 seconds after stopped engine.
- (2) After removal common rail fuel injection system and other related components, should be always clean.
- (3) When installing of fuel pipes(Part No: 09314-27110, 09314-27120, 09314-27130, 09314-3A000), do not fasten it at once, do it several times by torque as recommended.

(4) Caution with injector installation.

- When installing the injector removing SST(Special Service Tool), care not to interfere with any other parts.
- When installing the injector, clean it and replace the gasket with new one.
- Be sure to insert the injector into the hole on cylinder head uprightly without damage.
- Before installing injector, be sure to apply the diesel oil onto the gasket.



2) Caution for Injector Remover Usage

- (1) Try to know Manual well before using Injector Remover Tool.
- (2) When you install this tool to engine, make sure that there are no interference with other parts.
- (3) After installation, start to remove injector.
- (4) Do not exceed maximum torque for removing injector, not to cause any damages at cylinder head and head cover.
- (5) Problems as worker do not apply the right manual process(Especially, over Max. torques of each engines) can not be covered Warranty.

● Maximum Torque

- A, D, U, S-ENGINE : 10Kgf • m
- J-ENGINE : 25Kgf • m

5. How to use

1) Installation and Removal of A, D, U-Engine Injector

- (1) Disconnect battery's (-) terminal.
- (2) Remove injector connector after removing engine cover.
- (3) Remove return hose of injector after removing a high tension fuel pipe.
- (4) Remove injector fixing clamp.
- (5) Assemble Main Bar(parts 01) and Cross Bar temporarily(parts 02), by using Bar Holder A(parts 12), Bar Holder B(parts 13) and Bar Holder Bolt(parts 14). (Picture 01)
- (6) Install Sub Support A(parts17) to Main Support(parts16). (Picture 02)
- (7) By using 4 pieces of Support Mounting Bolt(parts 15), assemble Main Support(parts 16) to Cross Bar(parts 02) temporarily. (Picture 03, Picture 04)

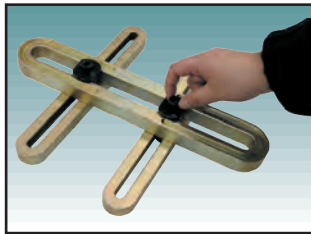

(Picture 01)

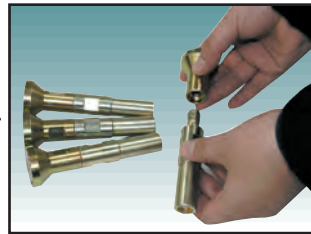

(Picture 02)

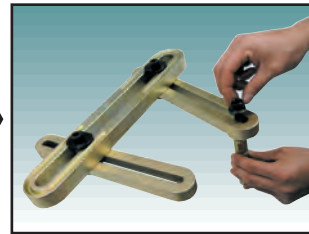

(Picture 03)

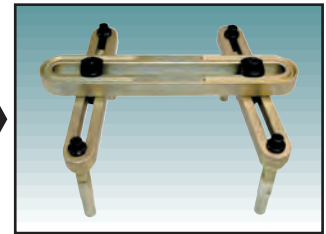

(Picture 04)

(8) Insert Injector Holder(parts 08) toward injector connector, install it to the lower end of injector. (Picture 05)

(9) Install Main Bolt(parts 06) to the upper end of Injector Holder-A(parts 08). (Picture 06)

(10) Install Injector Holder-B(parts 09) to the lower end of Injector. (Picture 07)

(11) Install Injector Holder Cover(parts 10) like Picture 08.



(Picture 05)



(Picture 06)



(Picture 07)



(Picture 08)

(12) Fasten Injector Holder Bolt(parts 11) at Injector Holder Cover(parts 10) by using 3mm L-wrench.

(Picture 09)

(13) Install the assembled tool on the upper end of 4pieces of engine head cover. (Picture 10)

⚠ Caution

- Be careful not to damage to neighboring parts when you install main bar assembly.
- Check cylinder head cover bolt is installed in (0.8~1.0kgf · m) before installation.

- (14) Fasten Bar Holder Bolt(parts 14) and Support Mounting Bolt(parts 15) by using 8mm L-Wrench.
(picture 11)

► **L-wrench Size**

Support Mounting Bolt(parts 15) and Bar Holder Bolt(parts 14) : 8mm

- (15) Install Main Bolt Holder(parts 03) on the Main bolt-A(parts 06). (picture 12)

⚠ Caution

- **Install projection part of Main Bolt Holder(parts 03) to Main Bolt Hole.**



(Picture 09)



(Picture 10)



(Picture 11)

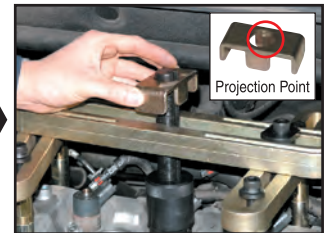

(Picture 12)

- (16) After installing ball bearing cover upward on Main Bolt Holder(parts 03), install Ball Bearing(parts 20) inside Ball Bearing Cover(parts 04). (picture 13)

⚠ Caution

- **Install bearing roller part side up.**

- (17) Install Main Nut(parts 05) on Main Bolt A(parts 06). (picture 14)

(18) Insert 32mm socket and exclude the injector by fastening it up slowly in a clockwise direction.

⚠ Caution

- Do not exceed maximum torque for removing injector, not to cause any damages at cylinder head and head cover.
- Maximum Torque : 10Kgf · m (A, D, U - Engine)

(19) In case of Picture 15,16 and 17 are showing removal of the injector after installing injector remover on A, D, U - Engine.

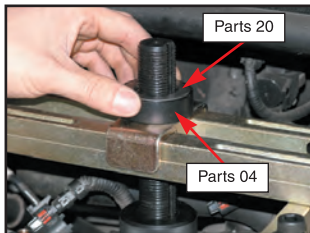

(Picture 13)



(Picture 14)



A - Engine



(Picture 15)

D - Engine



(Picture 16)

U - Engine



(Picture 17)

2) Installation and Removal of J-Engine Injector

- (1) Disconnect battery's (-) terminal.
- (2) Remove injector connector after removing engine cover.
- (3) Remove return hose of injector after removing a high tension fuel pipe.
- (4) Remove injector fixing clamp.
- (5) Assemble Main Bar(parts 01) and Cross Bar temporarily(parts 02), by using Bar Holder A(parts 12), Bar Holder B(parts 13) and Bar Holder Bolt(parts 14).(Picture 01)
- (6) Install Sub Support A(parts 17) to Main Support(parts 16). (Picture 02)
- (7) By using 4 pieces of Support Mounting Bolt(parts 15), assemble Main Support(parts 16) to Cross Bar(parts 02) temporarily.(Picture 03, Picture 04)

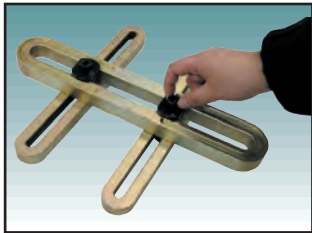

(Picture 01)

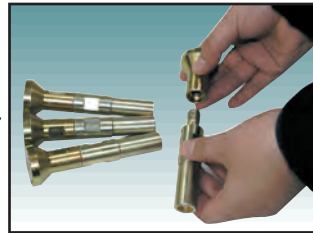

(Picture 02)

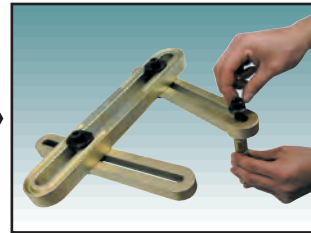

(Picture 03)

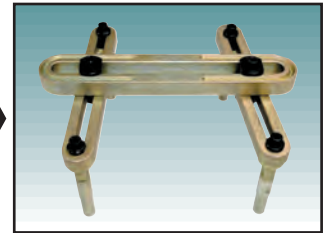

(Picture 04)

(8) Fasten up the Main Bolt (parts 07) until the end of screw part to the injector temporarily. (picture 05)

⚠ Caution

- Make it adjustable position of Main Bolt Holder(parts 03) and Main Bolt-B.

(9) Install the assembled tool(picture 04) on the top fixed four head bolt of engine head. (picture 06)

⚠ Caution

- Be careful not to damage to neighboring parts when you install main bar assembly.
- Check cylinder head cover bolt is installed in (0.9~1.1kgf • m) before installation.

(10) Fasten Bar Holder Bolt(parts 14) Support Mounting Bolt(parts 15) by using 8mm L-Wrench. (picture 07)

▶ **L-wrench Size**

Support Mounting Bolt(parts 15) and Bar Holder Bolt(parts 14) : 8mm

(11) Install Main Bolt Holder(parts 03) like picture 08.

⚠ Caution

- Install projection part of Main Bolt Holder(parts 03) to Main Bolt Hole.



(Picture 05)

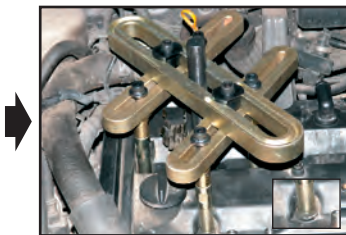

(Picture 06)



(Picture 07)



(Picture 08)

- (12) After installing ball bearing cover upward on Main Bolt Holder(parts 03), install Ball Bearing(parts 20) inside Ball Bearing Cover(parts 04). (Picture 09)

⚠ Caution

- When assembling Ball Bearing(parts 20) apply enough grease on ball bearing.

- (13) Install main nut(parts5) on Main bolt. (Picture 10)

⚠ Caution

- Apply enough grease before using Main Bolt-B(parts 07).

- (14) Insert 32mm socket and exclude the injector by fastening it up slowly in a clockwise direction.

⚠ Caution

- Do not exceed maximum torque for removing injector, not to cause any damages at cylinder head and head cover.
- Maximum Torque : 25Kgf · m (J - Engine)

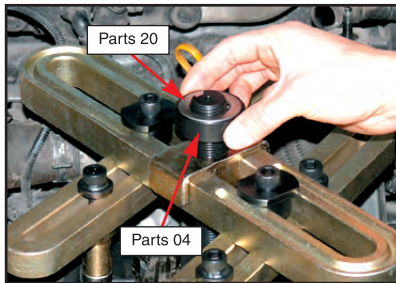

(Picture 09)



(Picture 10)

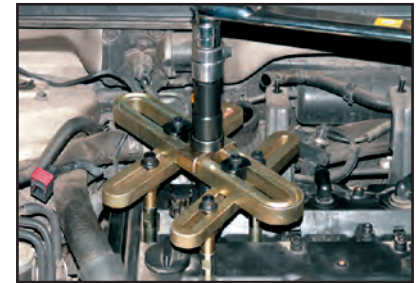

(Picture 11)

(15) Picture for selecting Engine head cover fixed bolt.

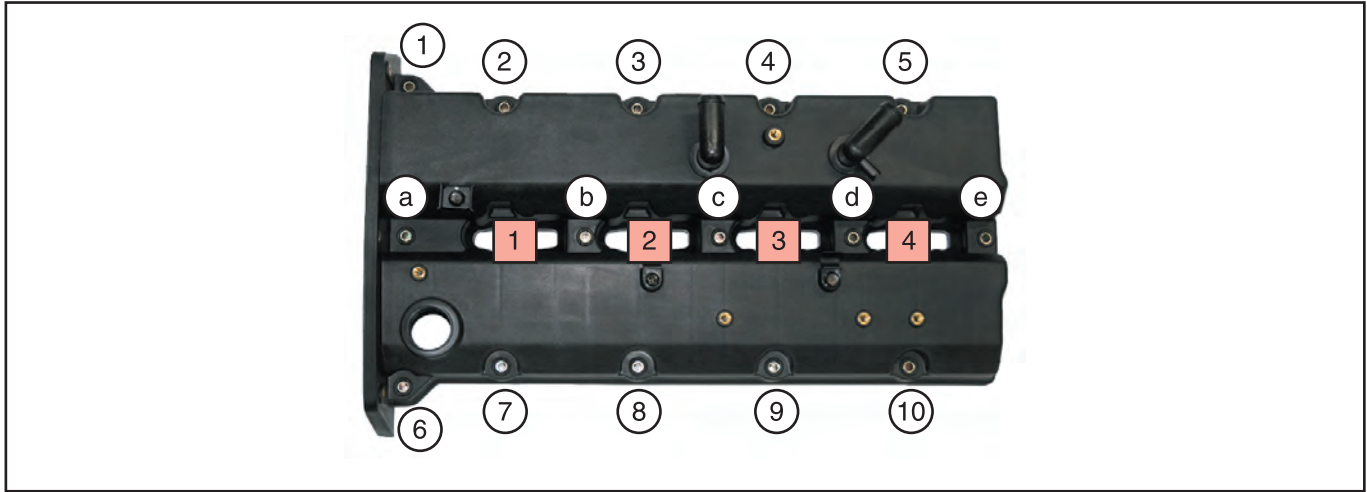

1 Fixed bolt : 2-b-a-7

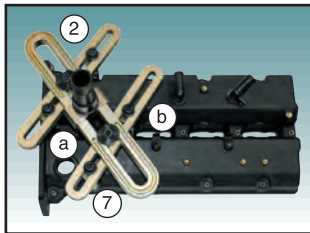

(Injector 1)

2 Fixed bolt : 3-c-7-8

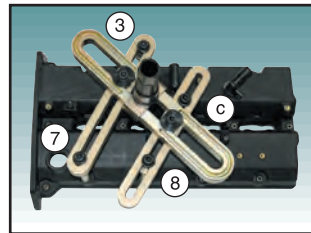

(Injector 2)

3 Fixed bolt : 4-d-8-9

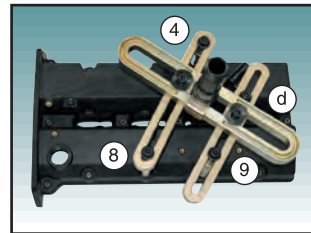

(Injector 3)

4 Fixed bolt : 5-e-9-10

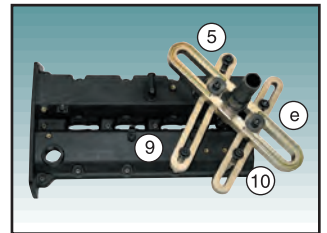

(Injector 4)

(16) Picture for installing Injector remover.

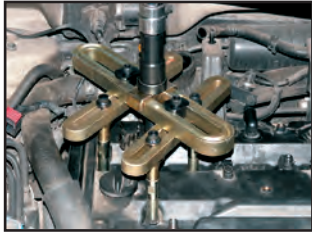

(Injector 1)



(Injector 2)



(Injector 3)

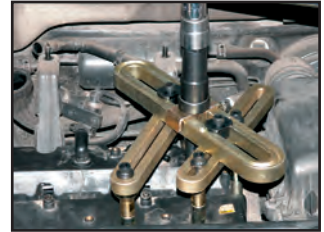

(Injector 4)

⚠ Caution

- If ball bearing is broken, it is commercially available.(Ball bearing No. : 51105)
- In case over near Max. torque 25kgf · m, apply lubricating oil to injector, after 6 hours work again.
Please make sure not exceed Max. torque 25kgf · m. If over it, can cause damage head cover, injector and injector remover sst.
- Please be careful! Problems as worker do not apply the right manual process, can not be covered Warranty.

3) Installation and Removal of S-Engine Injector

- (1) Disconnect battery's (-) terminal.
- (2) Remove injector connector after removing engine cover.
- (3) Remove return hose of injector after removing a high tension fuel pipe.
- (4) Remove injector fixing clamp.
- (5) Assemble Main Bar(parts 01) and Cross Bar temporarily(parts 02), by using Bar Holder A(parts 12), Bar Holder B(parts 13) and Bar Holder Bolt(parts 14). (Picture 01)
- (6) Install Sub Support B(parts 18) to Main Support(parts 16). (Picture 02)
- (7) By using 4 pieces of Support Mounting Bolt(parts 15), assemble Main Support(parts 16) to Cross Bar(parts 02) temporarily.(Picture 03, Picture 04)

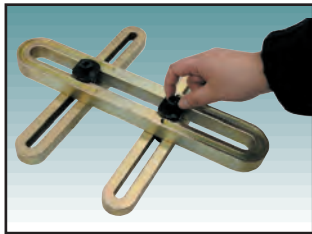

(Picture 01)



(Picture 02)



(Picture 03)



(Picture 04)

(8) Fasten up the Main Bolt (parts 06) until the end of screw part to the injector temporarily. (picture 05)

⚠ Caution

- Make it adjustable position of Main Bolt Holder(parts 03) and Main Bolt-A (parts 06).

(9) Install the assembled tool(picture 04) on the top fixed four head bolt of engine head. (picture 06)

⚠ Caution

- Be careful not to damage to neighboring parts when you install main bar assembly.
- Check cylinder head cover bolt is installed in (0.9~1.1kgf · m) before installation.

(10) Refer to the picture of Injector remover which placed top of bolt head. (picture 07)

(11) Fasten Bar Holder Bolt (parts 14) Support Mounting Bolt(parts 15) by using 8mm L-Wrench. (picture 08)

▶ L-wrench Size

Support Mounting Bolt(parts 15) and Bar Holder Bolt(parts 14) : 8mm



(Picture 05)

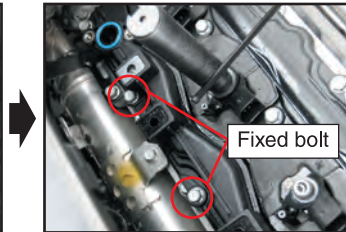

(Picture 06)



(Picture 07)



(Picture 08)

(12) Install the Main Bolt Holder(parts 03). (picture 09)

⚠ Caution

- **Install projection part of Main Bolt Holder(parts 03) to Main Bolt Hole.**

(13) After installing ball bearing cover upward on Main Bolt Holder(parts 03), install Ball Bearing(parts 20) inside Ball Bearing Cover(parts 04). (picture10)

(14) Insert the Main Nut-A(parts 05). (picture11)

(15) Insert 32mm socket and exclude the injector by fastening it up slowly in a clockwise direction. (picture12)

⚠ Caution

- **Do not exceed maximum torque for removing injector, not to cause any damages at cylinder head and head cover.**
- **Maximum Torque : 10Kgf · m (S - Engine)**



(Picture 09)

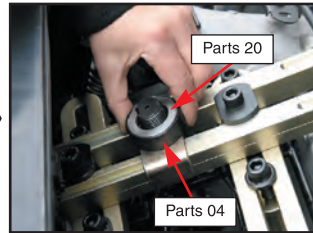

(Picture 10)



(Picture 11)



(Picture 12)



TAEYOUNG S.E.M. Co., Ltd.

The logo for TAEYOUNG S.E.M. Co., Ltd. is a blue stylized symbol consisting of three curved lines that meet at a central point, resembling a propeller or a fan.

206, 3Ba Block, Shihwa Industrial Complex,
Jungwang-1 Dong, Shiheung-City, Kyunggi-do, Korea
TEL : 82-31-497-7440, 497-7453 FAX : 82-31-497-7556
E-mail : expo@tysem.com Homepage : <http://www.tysem.com>

Pub No. : 09351-4A300-21

Printed in Korea

Dec. 2006